



INSTRUCTION MANUAL

Thank you for purchasing Aoyue Int2702 Lead-Free Repairing System.
It is important to read the manual before using the equipment.
Please keep manual in accessible place for future reference.



This manual is designed to familiarize and instruct the technician with the proper operation and maintenance of the equipment. The "Care and Safety Precautions" section explains the hazards of using any type of soldering or reworking device. Please read carefully and observe the guidelines in order to maximize usage and minimize the risk of injury or accidents .

Manufacturer:
AOYUE TONGYI ELECTRONIC EQUIPMENT FACTORY
Jishui Industrial Zone, Nantou, Zhongshan City,
Guangdong Province, P.R.China
<http://www.aoyue.com>

AIR NOZZLES*

Straight Single

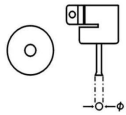

Nozzle Model	Nozzle Size, ϕ (mm)
1124	2.5
1130	4.4
1194	6
1195	8
1196	7
1197	9
1198	12

Bent Single

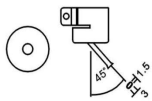

Nozzle Model	1142

Dual Single Adjustable

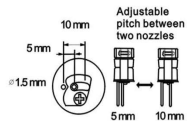

Nozzle Model	1325

Single In Line Package

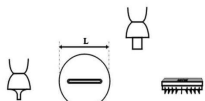

Nozzle Model	IC Package Size	Nozzle Length (mm)
1191	SIP 25L	26
1192	SIP 50L	52.5

Ball Grid Array

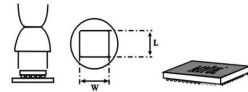

Nozzle Model	IC Package Size (mm)	Nozzle Size (mm)	
		W	L
1010	BGA 9x9	10	10
1313	BGA 12x12	13	13
1616	BGA 15x15	16	16
1919	BGA 18x18	19	19
2828	BGA 27x27	28	28
3636	BGA 35x35	36	36
3939	BGA 38x38	39	39
4141	BGA 40x40	41	41

Small Outline J-Lead



Nozzle Model	IC Package Size (mm)	Nozzle Size (mm)	
		L	W
1183	SOJ 15x8	16	8
1184	SOJ 18x8	19	10
1214	SOJ 10x26	25.9	12

Plastic Leaded Chip Carrier

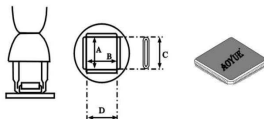

Nozzle Model	IC Package Size (mm)	Nozzle Size (mm)			
		A	B	C	D
1135	PLCC 17.5x17.5 (44pins)	18.5	18.5	15	15
1136	PLCC 20x20 (52pins)	21	21	19	19
1137	PLCC 25x25 (68pins)	26	26	24	24
1138	PLCC 30x30 (84pins)	31	31	29	29
1139	PLCC 7.3x12.5 (18pins)	9	14	69	69
1140	PLCC 11.5x11.5 (28pins)	13	13	15	10
1141	PLCC 11.5x14 (32pins)	15	13	15	10
1188	PLCC 9x9 (20pins)	11	11	10	10
1189	PLCC 34x34 (100pins)	36.5	36.5	33.5	33.5

Small-Outline Package

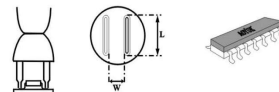

Nozzle Model	IC Package Size (mm)	Nozzle Size (mm)	
		L	W
1131	SOP 4.4x10	10	4.8
1132	SOP 5.6x13	15	5.7
1133	SOP 7.5x15	16	7.2
1134	SOP 7.5x18	19	7.2
1257	SOP 11x21	21	11.7
1258	SOP 7.6x12.7	11.7	8.2
1259	SOP 13x28	29	13.5
1260	SOP 8.6x18	19	8.7

Thin Small-Outline

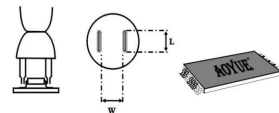

Nozzle Model	IC Package Size (mm)	Nozzle Size (mm)	
		L	W
1185	TSOL 13x10	10	11.9
1187	TSOL 18.5x8	10	18.5
1186	TSOL 18x10	11.7	18.2

Quad Flat Pack

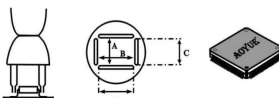

Nozzle Model	IC Package Size (mm)	Nozzle Size (mm)			
		A	B	C	D
1125	QFP 10x10	10.2	10.2	10	10
1126	QFP 14x14	15.2	15.2	15	15
1127	QFP 17.5x17.5	19.2	19.2	19	19
1128	QFP 14x20	15.2	21.2	15	21
1229	QFP 28x28	29.5	29.7	29	29
1215	QFP 42.5x42.5	42.5	42.5	40	40
1261	QFP 20x20	20.2	20.2	21	21
1262	QFP 12x12	12.2	12.2	12	12
1263	QFP 28x40	27.7	39.7	29	39
1264	QFP 40x40	40.2	40.2	39	39
1265	QFP 32x32	32.2	32.2	31	31

Bumpered Quad Flat Pack

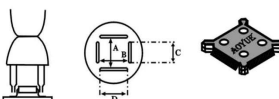

Nozzle Model	IC Package Size (mm)	Nozzle Size (mm)			
		A	B	C	D
1180	BGFP 17x17	18.2	18.2	13.6	13.6
1181	BGFP 19x19	19.2	19.2	16	16
1203	BGFP 35x35	35.2	35.2	30.6	30.6
1182	BGFP 24x24	24.2	24.2	21	21

TABLE OF CONTENTS

Product Description	4
Product Illustration	4
Package Inclusion	5
Specifications	6
Functions and Features	7
Safety Precautions	8
Assembly and Preparation	9
Control Panel Guide	10
Operating Guidelines	11 — 19
How to use the RESET button?	
How to use the CAL (calibration) utility?	
Initial Procedures	
Hot Air Gun	
Soldering Iron	
Desoldering Gun	
Auto-Stand-By Mode Timer (Hot Air Gun)	
Auto-Sleep Mode (Soldering Iron and Desoldering Gun)	
Care and Maintenance	20 — 21
Basic Troubleshooting Guide	22 — 24
Miscellaneous Section	25 — 26
Replacement Tips	
Air Nozzles	

(* Sold Separately)

PRODUCT DESCRIPTION

The Aoyue INT2702 Lead-Free Repairing System is a reworking equipment that combines the functionality of Hot Air Gun, Soldering Iron, Smoke Absorber, and Desoldering Gun in one sophisticated package.

One of the notable features of this device is the auto-cooling process of the Hot Air Gun. This functionality protects the device (and its components) from excessive heat by blowing air (at room temperature) upon reaching any of the following two conditions: (1) when the soldering gun remained idle on its resting handle after a certain period and (2) when the temperature of the device is above a safe threshold upon turning off. This will be discussed in greater detail together with the complete features in the succeeding sections of this manual.

Finally, the unique, innovative design with digital control panel and display provides precision, safety, and ease of use to match all reworking requirements.

PRODUCT ILLUSTRATION



REPLACEMENT TIPS*

Soldering Iron Tips With Heating Element

Suited for Aoyue Lead-Free Soldering Station Series, available in 2 sizes, LF and LF12.

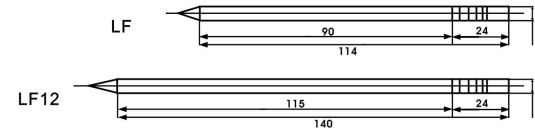

Bevel Type

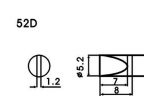
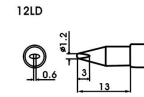
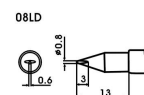
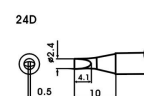
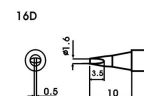
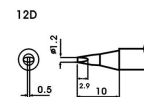
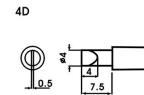
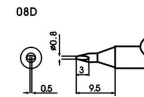

Chisel Type

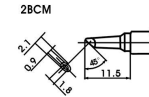
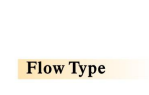
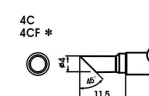
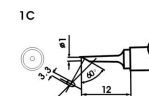
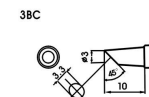
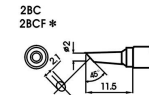
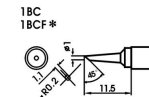

Conical Type

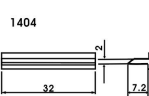
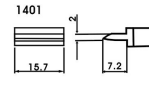
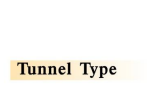
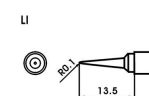
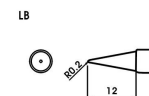
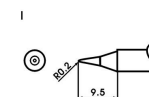
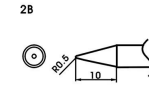
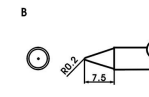

Blade Type

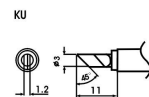
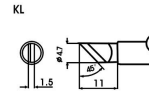
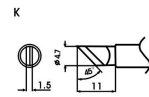

Sharp-Bent Type

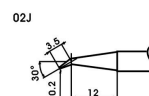

Flow Type

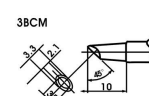
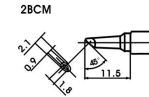

Tunnel Type

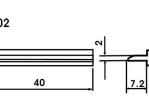
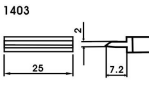
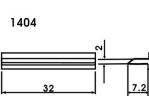
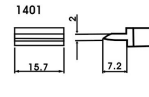

(* Sold Separately)

BASIC TROUBLESHOOTING GUIDE

PROBLEM 8: SOLDERING / DESOLDERING TEMPERATURE DISPLAY PANEL SHOWS UNRECOGNIZABLE CHARACTERS

Case 1: The system produces five (5) high beep sounds then shows something like "uuu" from the soldering / desoldering temperature display panel.



SOLUTION 1: Check if the soldering iron or the desoldering gun connection assembly is connected to the 6-pin receptacle of the control panel. Double check the pin connections if possible.

SOLUTION 2: Make sure the soldering iron tip is properly inserted and secured inside the handle. Loose contacts between the tip and handle can cause this error message.

Case 2: The system produces five (5) high beep sounds then shows something like "ttt" from the soldering / desoldering temperature display panel.



SOLUTION: The temperature of the desoldering gun fell below the minimum (< 200°C). Try to increase the temperature slightly until this error message ceases. Please also note of temperature fluctuations.

PROBLEM 9: DISPLAY AND OTHER DEVICE OPERATION ISSUES

SOLUTION: Try to press the RESET button on the device. Note that resetting the device will also reset all previously defined configurations.

OTHER PROBLEMS NOT MENTIONED:

Contact the vendor.

PACKAGE INCLUSION

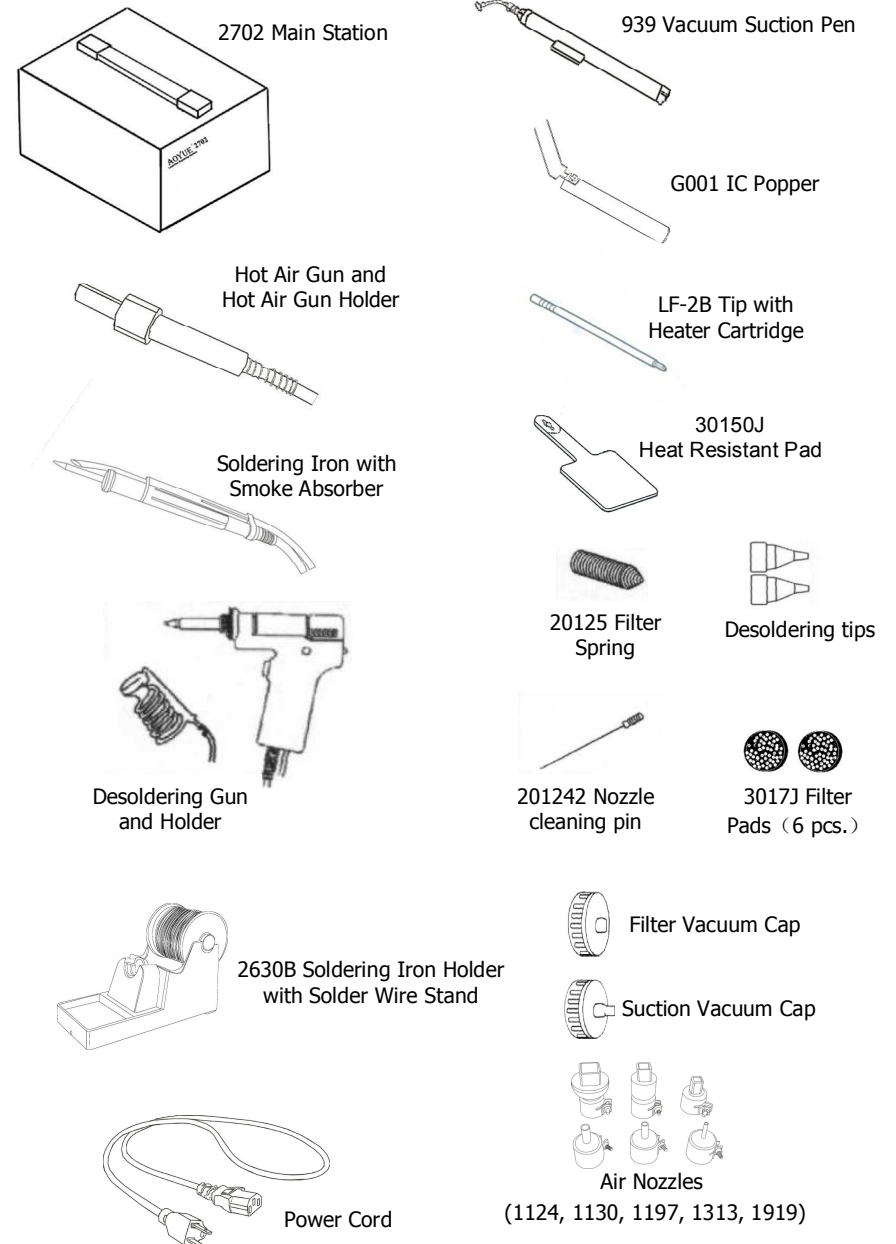

SPECIFICATIONS

MAIN STATION	
Power Input :	available in 110V / 220V
Station Dimensions:	188(w) x 126(h) x 250(d) mm
Weight:	5.6Kg
SOLDERING IRON	
Power Consumption:	70W
Temperature Range:	250°C - 480°C
Heating Element:	Ceramic Heater
Output Voltage:	24V
HOT AIR GUN	
Power Consumption:	500W
Temperature Range:	100°C - 480°C
Heating Element	Metal Heating Core
Pump/Motor Type:	Diaphragm Pump
Air Capacity:	23 l /min (max)
DESOLDERING GUN	
Temperature Range:	380°C - 480°C
Heating Element:	Ceramic Heater
Output Voltage:	36V
Suction Flow:	15 l /min (max)
Vacuum Generator:	Vacuum Pump
Vacuum Pressure:	600mm Hg

BASIC TROUBLESHOOTING GUIDE

PROBLEM 6: THE UNIT IS VERY NOISY

SOLUTION: Make sure the screw at the center of the base of the main unit has been removed. This holds the pump in place during transportation and needs to be removed before using the equipment.

PROBLEM 7: AIR PRESSURE LEVEL IS SIGNIFICANTLY LOW NO MATTER HOW HIGH THE AIRFLOW LEVEL IS CALIBRATED

Case 1: Check the mains voltage (AC power source). If the voltage level falls significantly low, about 15-20% lower than the standard, there will also be a noticeable drop in the air pressure level.

SOLUTION: Please refer to your local power service provider.

Case 2: The microcontroller might have detected the operating frequency incorrectly. The user will notice that airflow level is weaker with reference to the airflow gauge compared with the displayed value.

SOLUTION: Try to press the RESET button on the panel to let the device re-detect the proper operating frequency. Note that resetting the device will also reset all previously defined configurations to system default parameters.

Case 3: The Suction Vacuum cap is connected to the Smoke Absorber Terminal or Vacuum cap instead of the Filter Vacuum cap.

SOLUTION: Change the cap to the Filter Vacuum cap or the cap with the wider mouthpiece. This allows more air to pass through the system. Make sure as well that the vacuum tube of the soldering iron or desoldering gun is not connected.

Case 4: The Filter Vacuum cap is connected but airflow level is still low.

SOLUTION: Check the filter pad inside the vacuum cap for dirt that can block the air passage. Clean or replace if necessary.

ADDITIONAL SOLUTION: Check for any tangles in the tube of the hot air gun that can cause the air blockage.

BASIC TROUBLESHOOTING GUIDE

PROBLEM 1: THE UNIT HAS NO POWER

1. Check if the unit is switched ON.
2. Check the fuse. Replace with the same type if fuse is blown.
3. Check the power cord and make sure there are no disconnections.
4. Verify that the unit is properly connected to the power source.

PROBLEM 2: TEMPERATURE DISPLAY IS ALWAYS ABOVE 500°C

Description: Constant display of above 500°C temperature from the panel then displays a blinking "OFF" on the panel after a few minutes.

SOLUTION:

The thermal sensor may be broken and needs to be replaced.

PROBLEM 3: ACTUAL AIR TEMPERATURE IS NOT INCREASING

Description: Actual temperature reading is not increasing or decreasing based on desired level. The panel will then display a blinking "OFF" on panel.

SOLUTION:

The heating element may be broken and needs to be replaced.

PROBLEM 4: BANNER OR PRODUCT NAME IS ALWAYS SCROLLING - THE UNIT IS NOT USABLE

Description: The product name is always just scrolling from the digital panel, rendering the device unusable.

SOLUTION: Try to press RESET from the control panel. Note that resetting the device will also reset all previously defined configurations.

PROBLEM 5: THE UNIT IS VIBRATING TOO MUCH

Check if the 4 screws that hold the pump in place are properly and tightly connected. Unplug the system from the main power source before opening the case to check the internal settings.

FUNCTIONS and FEATURES

- Microprocessor-controlled ESD safe equipment.
- 3-in-1 repairing system combining Hot Air Gun, Soldering Iron, and Desoldering Gun in one sophisticated package.
- Digital control and display of hot air temperature, soldering iron temperature, desoldering gun temperature and air pressure with touch type panel controls for precision and ease of use.
- The desoldering gun is equipped with air cylinder type vacuum pump for stronger suction and zero-crossing circuit that prevents electrical surges.
- Integrated smoke absorber functionality.
- Uniquely designed compound tip that integrates the ceramic heating element and sensor in just one component. Replacing tips is as easy as slipping it in/out of the compatible 24V soldering iron.
- User-configurable 1- to 20-minute idle-to-auto-stand-by mode (with 5 minutes as default) for additional device protection and power saving.
- Built-in auto-cooling process that protects the system and its components from excessive heat, prolonging usage life.
- Built-in auto-sleep mode for soldering iron and desoldering gun.
- Compatibility with air nozzles of various types.
- Compatibility with different kind of soldering tips.

SAFETY PRECAUTIONS



CAUTION: Improper usage can cause serious injury to personnel and/or damage to equipment and work area. For your own safety, please observe the following precautions.

- Check each component after opening the package to make sure everything is in good condition. If there are any suspected damage, do not use the item and report the issue to your vendor.
- Turn OFF the main power switch and unplug the device from the main power source when moving the device from one location to another.
- Do not strike or subject the main unit (and all its components) to physical shock. Use carefully to avoid injury and damage to any part.
- Handle with care.
 - Never drop or sharply jolt the unit.
 - Contains delicate parts that may break if the unit is dropped.
- Make sure the equipment is always grounded. Always connect power to a grounded receptacle.
- Temperature may reach as high as 480°C when switched ON.
 - Do not use the device near flammable gases, paper and other flammable materials.
 - Do not touch heated parts, which can cause severe burns.
 - Do not touch metallic parts near the tip.
- Disconnect the plug from the power source if the unit will not be used for a long period.
 - Turn off power during breaks, if possible.
- Use only genuine replacement parts.
 - Turn off power and let the unit cool before replacing parts.
- The unit may produce a small amount of smoke and unusual odor during initial usage. This is normal and should not yield any negative result when reworking.
- Soldering process produces smoke — use on well ventilated place.
- Do not alter the unit, specifically the internal circuitry, in any manner.

CARE and MAINTENANCE

Checking the soldering iron connection cord for damages

1. Remove the soldering tip and the nipple.
2. Push the socket out from the handle assembly.
3. Measure the resistance values between the connector and the lead wires at the socket as follows:

Pin 1 - Red (+)

Pin 3 - Blue (ground)

Pin 5 - Black (-)

If any value exceeds 0Ω (shorted) or ∞ (infinitely large — open), replace the handle assembly.

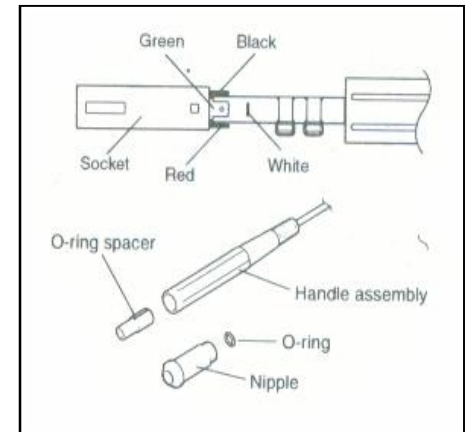

Replacing the heating element of the Hot Air Gun

The heating element is found in the middle part of the hot air gun. The normal life of a heating element is 1 year under normal operating conditions.

Steps:

1. Loosen the 3 screws that secure the handle.
2. Slide off the plastic tube.
3. Disconnect the ground wire sleeve.
4. Inside the pipe, the quartz glass and heat insulation are installed. Loosen the cable and take out the heating element.
5. Insert new heating element and reconnect the terminal. *Be careful not to rub Heating Element wire.*
6. Reconnect the ground wire after replacing the element.
7. Assemble the handle again.

CARE and MAINTENANCE

Blower/Vacuum Air Terminal Filters

Filters should be cleaned and replaced regularly to avoid dirt which can clog the air passage. More importantly, this will also effectively clean the toxic fumes produced during soldering process.

Soldering Iron Tip

Always keep the solder-plated section of the tip/nozzle coated with a small amount of solder. Oxide coating on the tip of the nozzle reduces its heat conductivity. Coating the tip with a small amount of fresh solder ensures maximum heat conductivity is obtained.

Replacing the Soldering Iron tip

1. Always turn OFF main power switch when removing or inserting a tip.
2. If the tip is hot, use the heat resistant pad to pull it out.
3. Insert the new tip fully into the handle. If the tip is not fully inserted (or if the tip is damaged), the device will produce five high beep sounds then show the following from the SOLDER/DESOLDER TEMPERATURE display panel ("13").



Spare Parts Guide

Part No.	Description
10094	Hot air gun heating element
30106S	Plastic handle of hot air gun
S009	Hot air gun complete handle
20962	Hot air gun metal pipe
B012	Soldering Iron complete handle
C005	Desoldering gun heating element
3072D	Plastic handle of desoldering gun
B1003	Desoldering gun complete handle

ASSEMBLY and PREPARATION

A. Aoyue Int2702 Main Station

As soon as the equipment has been removed from the package, **REMOVE THE SCREW** located at the center of the bottom of the main unit. This screw holds the pump in place during transportation.

 **WARNING:** Failure to remove the screw before using the equipment can cause damage to the system.

B. Soldering Iron

1. Install the solder wire to the soldering iron holder as in Figure 1.

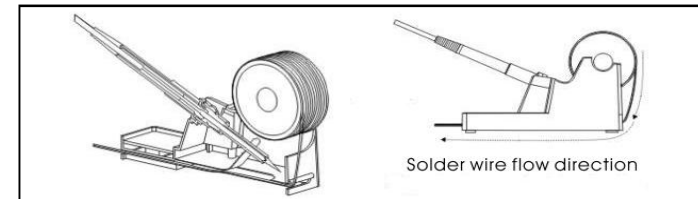

Figure 1. Soldering iron stand with solder wire holder

2. Connect the soldering iron cord assembly to the 6-pin output terminal found at the lower middle portion of the main unit.
3. Place the soldering iron to the soldering iron stand as shown above.

C. Smoke Absorber

1. Attach the smoke absorbing tube to the suction vacuum cap. Make sure the cord connections are free from tangles.

D. Hot Air Gun

The Hot Air Gun holder was installed on the station upside down for packaging purpose. To set up the Hot Air Gun holder:

1. Loosen the two screws that secure the holder to the station.
2. Turn the holder right side up.
3. Re-fasten the two screws.
4. Place the hot air gun onto the holder in preparation for usage.

E. Desoldering Gun

1. Connect the cord assembly of the Desoldering Gun to the 6-pin terminal .
2. Connect the vacuum tube to the suction vacuum cap.
3. Place the desoldering gun onto the holder in preparation for usage.

CONTROL PANEL GUIDE

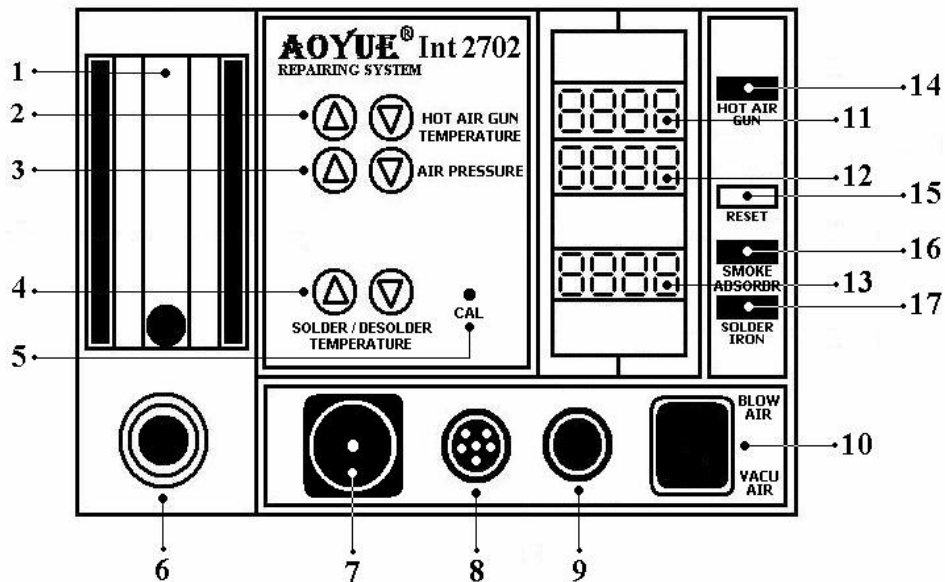

LEGEND:

- 1 — Airflow Gauge
- 2 — Hot Air Gun Temperature Adjustment Buttons
- 3 — Hot Air Gun Airflow Adjustment Buttons
- 4 — Soldering Iron / Desoldering Gun Temp Control Buttons
- 5 — Calibration Utility Terminal
- 6 — Hot Air Gun Output Terminal
- 7 — Smoke Absorber Terminal or Vacuum Cap
- 8 — Soldering Iron / Desoldering Gun 6-Pin Receptacle
- 9 — Main Power Switch
- 10 — Blower / Vacuum Activation Switch
- 11 — Hot Air Gun Temperature Display
- 12 — Hot Air Gun Air Pressure Display
- 13 — Soldering Iron / Desoldering Gun Temperature Display
- 14 — Hot Air Gun Activation Switch
- 15 — Reset Button
- 16 — Smoke Absorber Switch
- 17 — Soldering Iron / Desoldering Gun Activation Switch

OPERATING GUIDELINES

ADDITIONAL NOTES on AUTO-SLEEP MODE

1. The default time before the soldering iron or the desoldering gun goes to sleep mode is 30 minutes. This is also fixed and non-configurable.
2. Once the system determines that the time has elapsed, it will gradually decrease the temperature of the soldering iron or the desoldering gun then show the following from the display panel of the SOLDER/DESOLDER TEMPERATURE.



3. To deactivate the auto-sleep mode, deactivate the SOLDER IRON then activate it again, this time, without holding the Soldering / Desoldering Temperature Adjustment buttons. Note that pressing this will also remove the previous temperature value. Re-adjustment may be

ADDITIONAL NOTES on SOLDERING IRON and DESOLDERING GUN

1. Because of the difference in the heating element and size of the soldering iron tip and desoldering gun, the soldering iron will heat up faster than the desoldering gun. This is normal and does not have any impact on the system's performance.
2. There will be a slight drop in temperature display once the trigger of the desoldering gun is used. This is due to rapid intake of air in which temperature is significantly cooler than the desoldering gun tip. When the system detects this, it will automatically adjust the temperature to compensate for the temperature difference.

OPERATING GUIDELINES

F. Activating Soldering Iron & Desoldering Gun Auto-Sleep Mode

Aside from the auto stand-by mode feature of the hot air gun, the device has a separate mechanism to put the soldering iron or desoldering gun into SLEEP mode after a certain period. By default, this is deactivated and the user must do any of the following two sets of procedures (whichever is applicable) in order to activate this feature.

CONDITION 1: Device is initially switched OFF (main power switch OFF)

1. Make sure all function switches are deactivated.
2. Turn ON the main power switch.
3. Hold both UP and DOWN buttons of the SOLDER/DESOLDER TEMPERATURE Adjustment buttons.
4. Activate the SOLDER IRON switch while still holding both the UP and DOWN buttons from the previous step.
5. Make sure the following was momentarily shown from the soldering iron / desoldering gun temperature display panel ("13" from the control panel).
6. Release the two buttons to put the device into operation.



CONDITION 2: Device is already switched ON

1. Hold both UP and DOWN buttons of the SOLDER/DESOLDER TEMPERATURE Adjustment buttons.
2. Press the RESET button once while still holding the two buttons from the previous step.
3. Make sure the same display above was momentarily shown from the soldering iron / desoldering gun temperature display panel.
4. Release the two buttons to put the device back into operation.

NOTE: The auto sleep feature is automatically deactivated when the device is switched OFF or when the RESET button is pressed without doing the procedures specified above.

OPERATING GUIDELINES

IMPORTANT REMINDERS:

1. Make sure the equipment is placed on a flat stable surface and all the heat-generating components placed on their respective holders or stands.
2. Ensure all function switches are OFF prior to reworking.
3. Ensure all terminal connections are properly secured.

 **IMPORTANT:** Please refer to the **CONTROL PANEL GUIDE** page for buttons and display panel directory.

How to use the RESET button?

The RESET button ("15" from the control panel) is used to reconfigure temperature and airflow level settings. In very rare cases, this may also solve some minor display or operation issues (see BASIC TROUBLESHOOTING GUIDE for further details). When pressed, the system will temporarily switch to stand-by mode then start the device using factory default operating parameters (provided the respective function switch is activated):

Hot Air Gun Temperature:	100°C
Hot Air Gun Airflow Level:	51
Soldering Iron Temperature:	350°C

NOTE: Pressing the RESET button removes user-configured system values. Reconfiguration may then be necessary.

How to use the CAL (calibration) utility?

In special cases, it may be necessary to synchronize the amount of heat delivered by the soldering iron with an external temperature sensing device. This can be achieved by slowly tuning the CAL or calibration utility ("5" from the control panel) using a small screw driver until the approximate operating temperature on both devices are synchronized.

OPERATING GUIDELINES

A. INITIAL PROCEDURES

1. Plug the device to the main power source using the power cord provided in the package.
2. With all function switches deactivated and all terminal connections properly secured, switch ON the device by activating the main power switch ("9" from the control panel).

IMPORTANT: Initial control panel setting includes the BLOWER/VACUUM ACTIVATION switch ("10" from control panel) set to **"Blow Air"**.

3. The display panels, 11 and 12 will temporarily show the product name in a scrolling manner and then display "OFF" on both rows once the scroll is finished (see below illustration). The system will remain at this state until the user activates a function.

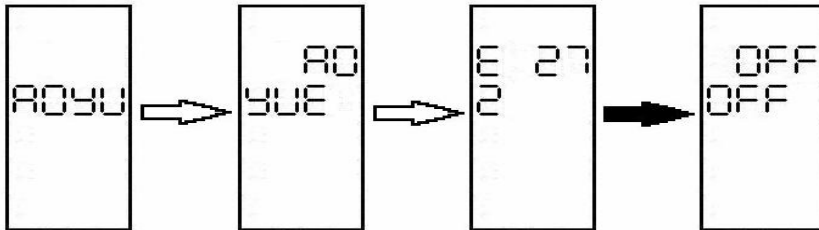

B. HOT AIR GUN

1. Follow the initial procedures above, "**A. INITIAL PROCEDURES**".
2. Activate "Hot Air Gun" switch ("14" from the control panel).
3. The system will immediately start to blow air at an airflow rate of **51** while rapidly and safely increasing the air temperature to **100°C** (default system operating parameters). These values will be reflected from the Hot Air Gun Air Temperature and Air Pressure display panels, "11" and "12" from the control panel, respectively. The metal ball inside the air gauge ("1" from the control panel) will also settle somewhere in the middle of the visible area indicating that the system is blowing air at an average or normal rate. (See illustrations on the next page.)

OPERATING GUIDELINES

E. Auto-Stand-By Mode (Hot Air Gun)

The device has a built-in timer such that if the Hot Air Gun sits on its handle and remain idle for a certain period, the device will switch indefinitely to stand-by mode (provided the power delivered to the system remain uninterrupted). Once the countdown time has elapsed, the system will blow air (at room temperature) at a maximum rate in order to bring down the temperature. During this time, the prefix of the display for Hot Air Gun air temperature will change from "A" to "d". Once the temperature drops to approximately 90°C, the Hot Air Gun will automatically stop and show an all-dash display indicating that the system is now on stand-by.

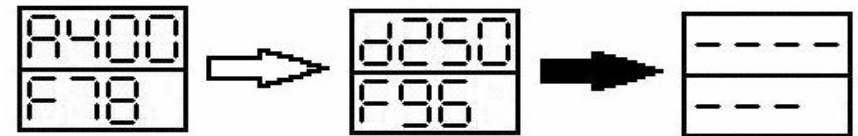

The device will automatically switch back into operation with the last user-defined parameters, i.e., hot air gun temperature, airflow level, etc., when the Hot Air Gun is lifted again from the handle.

By default, the system has a 5-minute countdown time. This can be altered by the following procedures.

1. Upon system start-up, while the product name is scrolling from the display panel, hold the **UP** button of the AIR PRESSURE Adjustment buttons and wait until "**L05**" is displayed.
2. Adjust the time using the **UP** and **DOWN** buttons of the HOT AIR GUN TEMPERATURE Adjustment buttons.
3. Confirm the change by pressing the **DOWN** button of the AIR PRESSURE Adjustment buttons.
4. The system will automatically switch back into operation and use the defined countdown parameter.

ADDITIONAL NOTES:

1. The alternative to first step above is to press the **RESET** button then hold the UP button of the AIR PRESSURE Adjustment buttons until "L05" is displayed. Note that pressing RESET removes user-defined configurations.
2. The countdown timer is configurable between **1** and **20** minutes.

OPERATING GUIDELINES

D. DESOLDERING GUN

1. Connect the Desoldering Gun connection assembly to the 6-pin receptacle at the front of the control panel ("8" from CONTROL PANEL GUIDE).
2. Follow the initial procedures ("A. INITIAL PROCEDURES").
3. Connect the vacuum tube to the Smoke Absorber Terminal or Vacuum Cap ("7" from the control panel).
4. **IMPORTANT:** Set the BLOWER or VACUUM ACTIVATION switch to "Vacuum Air".
5. Activate the "SOLDER IRON" Activation switch ("17" from control panel). This will automatically start to increase the temperature of the

NOTE: The system will produce a high beep sound when the default temperature (or when the desired temperature) is reached.

6. Adjust the desoldering gun temperature using the SOLDER/DESOLDER TEMPERATURE ADJUSTMENT buttons ("4" from the control panel).
7. You may start using the desoldering gun when the desired temperature is reached. Use the trigger of the desoldering gun to pick up unnecessary solder leads.
8. When desoldering task is finished, deactivate the SOLDER IRON switch.
9. Set the BLOWER/VACUUM ACTIVATION switch back to "Blow Air".
10. Detach the desoldering gun connection assembly from the 6-pin receptacle at the control panel as well as the vacuum tube from the vacuum cap (if necessary).
11. Allow sufficient time for the desoldering gun to cool down before keeping in a safe storage. (Optional but recommended)

NOTE: The soldering iron and desoldering gun operating temperature is configurable between **200°C** and **480°C**.

⚠ IMPORTANT: Make sure the SMOKE ABSORBER switch is deactivated while using the desoldering gun. Otherwise, the desoldering gun will keep on sucking air indefinitely.

OPERATING GUIDELINES

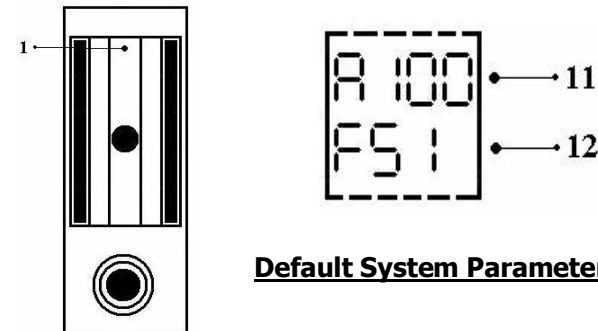

Default System Parameters (Hot Air Gun)

4. Adjust the air flow level using the AIR PRESSURE ADJUSTMENT BUTTONS ("3" from the control panel). The prefix of the display for Air Pressure will change from "F" to "E" while air flow level is being adjusted. It will return to "F" as soon as the desired level is reached. In the case below, the final airflow level is "F89".



5. Adjust the hot air gun air temperature using the HOT AIR GUN TEMPERATURE ADJUSTMENT BUTTONS ("2" from the control panel). The prefix of the display for Hot Air Gun Temperature will change from "A" to "b" indicating that air temperature is being adjusted. It will return to "A" while the temperature is gradually increasing or decreasing until the desired temperature is reached. In the example below, final air gun temperature is "A380".

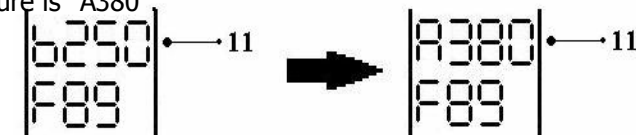

⚠ IMPORTANT: When adjusting the air temperature, it is strongly advised to initially increase the airflow level in order to manage the system temperature. This is to protect the heating element inside the handle from excessive heat and avoid the possibility of subjecting adjacent components to thermal shock.

OPERATING GUIDELINES

- Reworking task can be started as soon as the desired hot air temperature and airflow level are reached, as also indicated from display panels "11" and "12", respectively.
- When reworking is complete, return the Hot Air Gun to its holder and **DO NOT** immediately turn off the main power switch.
- Deactivate the Hot Air Gun Activation button first in order to activate the auto-cooling process. The system will start to blow air (at room temperature) at a fast rate to reduce heat from the hot air gun and bring down the temperature to a reasonable safe level of **90°C**. During this time, the prefix of the display for hot air gun temperature will also change from "A" to "E" while temperature is gradually decreasing. Likewise, the air pressure level is at its highest reading as indicated from the display panel. Once the temperature drops to approximately **90°C** the system will halt and display "OFF" on the panel. It is now safe to switch off the main power switch. See illustration below.

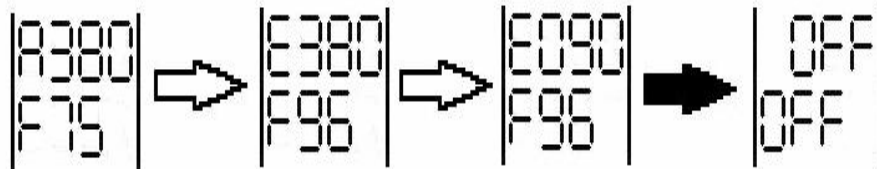

Before Deactivating
Hot Air Gun Function Switch

After Deactivating
Hot Air Gun Function Switch

- Turn OFF the main power switch.
- Unplug the device from the main power source.

NOTES:

- Hot Air Gun Temperature is adjustable between **100°** and **480°C** with an increment of **10°** on each step.
- Hot Air Gun Airflow Rate is adjustable between **6** and **99** with an increment of **3** on each step.

OPERATING GUIDELINES

C. SOLDERING IRON

- Connect the Soldering Iron connection assembly to the 6-pin receptacle located at the front of the control panel ("8" from the CONTROL PANEL GUIDE).
- Follow the initial procedures ("**A. INITIAL PROCEDURES**").

IMPORTANT NOTE: Steps 3, 4, 7, 9, and 11 are optional when using only the soldering iron. If the smoke absorber functionality will be used, these procedures are required.

- Connect the vacuum tube to the Smoke Absorber Terminal or Vacuum Cap ("7" from the control panel).
- IMPORTANT:** Set the BLOWER or VACUUM ACTIVATION switch to "**Vacuum Air**".
- Activate the "SOLDER IRON" Activation switch ("17" from control panel). This will automatically start to increase the temperature of the soldering iron to **350°C** (default).

NOTE: A high beep sound will be heard when the default temperature (or when the desired temperature) is reached.

- Adjust the soldering iron temperature using the SOLDER/DESOLDER TEMPERATURE ADJUSTMENT buttons ("4" from the control panel).
- Activate the "SMOKE ABSORBER" Activation switch ("16" from the control panel).
- Start using the soldering iron as soon as desired temperature is reached.
- When the task is finished, deactivate the SMOKE ABSORBER switch.
- Deactivate the SOLDER IRON activation switch.
- Set the BLOWER/VACUUM ACTIVATION switch back to "**Blow Air**".
- Detach the soldering iron connection assembly from the 6-pin receptacle at the control panel as well as the vacuum tube from the vacuum cap (if necessary).
- Allow sufficient time for the soldering iron to cool down before keeping in a safe storage. (Optional but recommended)